

更改 REV	設 變 內 容 MODIFICATION	日 期 DATE	修 改 DRAW	核 准 APPROVE
E	EN900108	1/04/90	DRAGON	STEVEN
F	EN9010029	10/09/90	JULIA	MORRIS
G	EN9011097	11/29/90	JULIA	MORRIS

NOTES:

- MATERIAL/FINISH :
 PLASTIC BODY : HIGHT TEMPERATURE THERMOPLASTIC UL94V-0
 CONTACT : COPPER ALLOYS
 MOUNT EAR : COPPER ALLOYS
 CONTACT AREA : GOLD PLATING OVER Pd/Ni
 PLATING Ni UNDER PLATING.
 SOLDER TAIL AREA : TIN LEAD PLATING
 MOUNT EAR : TIN PLATING Ni UNDER PLATING.
 SOLDER TAIL TO BE WITHIN 0.05 UPWARD AND 0.2 DOWNWARD FROM Z-DATUM PLACE, AND COPLANALITY OF SOLDER TAILS TO BE WITHIN 0.12. MEASUREMENT POINT IS SOLDER TAILS TIP.

3. PLEASE REFER TO TABLE 1 FOR TERMINAL LENGTH.

TABLE 1

PIN NUMBER	DIM. L±0.10
25, 26	3.50
ALL OTHER PINS	4.25
1, 13, 38, 50	5.00

4. MARK Δ SPECIFY PIN 1 LOCATION (CIRCUIT NUMBER 1)

5. P/N. : N012-0 1 0 0-0 0 X

- HOUSING STYLE
 0. STANDARD TYPE W/NUT HEXAGON HOLE
- NUT OPTION
 1. WITHOUT NUT
 2. WITH NUT
- EAR OPTION
 0. NORMAL EAR
 2. MOUNT WITH SCREWTHREAD(M2)
- CONTACT AREA PLATING
 1= Pd/Ni 40 μ "
 2= Pd/Ni 30 μ "
 3= Pd/Ni 20 μ "
 4= Pd/Ni 10 μ "
 5= AU 30 μ "

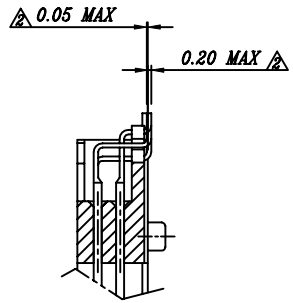
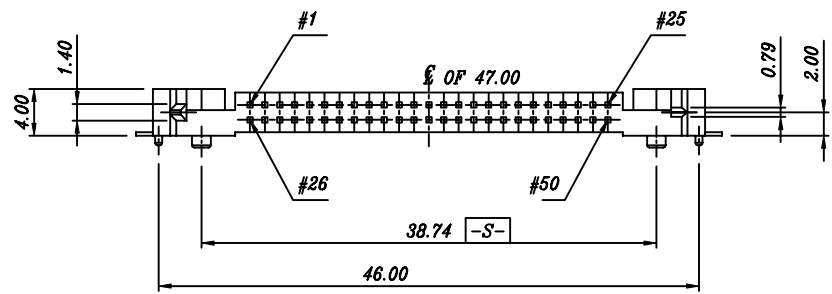
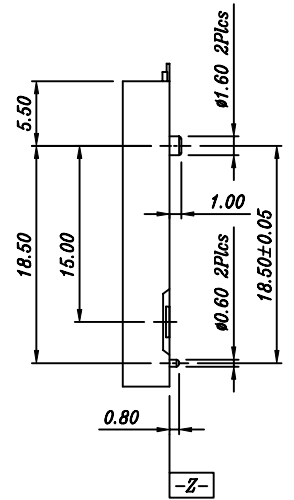
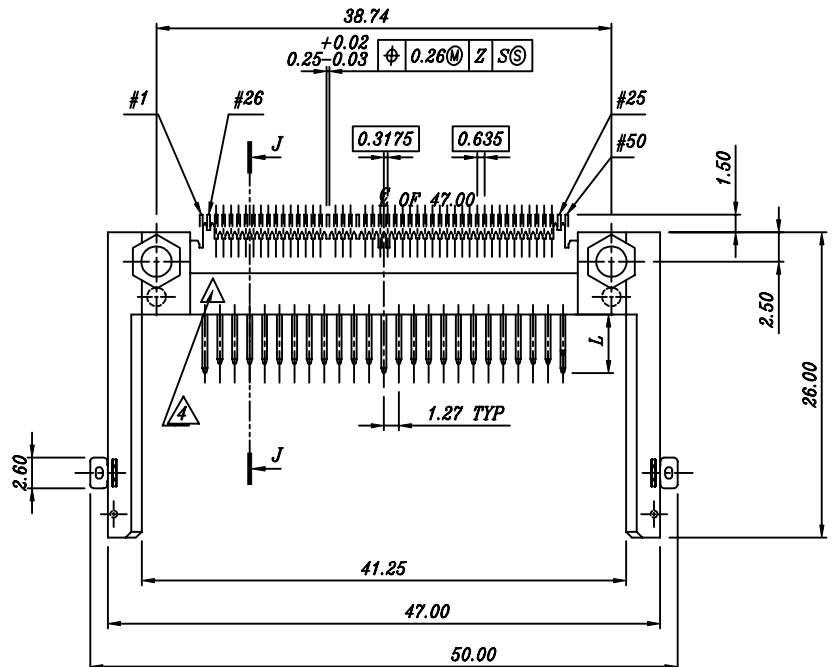

SECTION A-A
SCALE 1.5:1

DIMENSION IN mm [Inch]		產品規範 PROD. SPEC.		宣得股份有限公司 TECH SPEED TECH CORP.	
TOLERANCE UNLESS OTHERWISE SPECIFIED		SPEC 0027		案 號 FILE NO.	
.X±	X.°±	包裝規範 PKG. SPEC.	AAA-N012-0001	圖 號 DWG NO.	N01-0013-0001
.XX±0.15	.X°±	製 圖 DRAW 90.11.29			
XXX±	.XX°±	角 法 PROJ.			
名稱 TITLE		CF HEADER LOW-PROFILE NORMAL TYPE 1 1.27mm PITCH D/R		圖 數 SHEET 1 / 4	
審 核 APPROVE		核 對 CHECK		比 例 SCALE	
MORRIS		MORRIS		1.5:1	
		製 圖 DRAW 90.11.29		圖 紙 SIZE A4	
				更 改 REV G	

CUSTOMER DRAWING

更改 REV	設變內容 MODIFICATION	日期 DATE	修改 DRAW	核准 APPROVE
E	EN900108	1/04/90	DRAGON	STEVEN
F	EN9010029	10/09/90	JULIA	MORRIS
G	EN9011097	11/29/90	JULIA	MORRIS

NOTES:

- MATERIAL/FINISH :
 PLASTIC BODY : HIGH TEMPERATURE THERMOPLASTIC UL94V-0
 CONTACT : COPPER ALLOYS
 MOUNT EAR : COPPER ALLOYS
 CONTACT AREA : GOLD PLATING OVER Pd/Ni
 PLATING Ni UNDER PLATING.
 SOLDER TAIL AREA : TIN LEAD PLATING
 MOUNT EAR : TIN PLATING Ni UNDER PLATING.
 ⚠ SOLDER TAIL TO BE WITHIN 0.05 UPWARD AND 0.2 DOWNWARD FROM Z-DATUM PLACE, AND COPLANALITY OF SOLDER TAILS TO BE WITHIN 0.12. MEASUREMENT POINT IS SOLDER TAILS TIP.

3. PLEASE REFER TO TABLE 1 FOR TERMINAL LENGTH.

TABLE 1

PIN NUMBER	DIM. L±0.10
25, 26	3.50
ALL OTHER PINS	4.25
1, 13, 38, 50	5.00

⚠ MARK △ SPECIFY PIN 1 LOCATION (CIRCUIT NUMBER 1)

5. P/N. : N012-0 1 2 0-0 0 X

- NUT OPTION
 1. WITHOUT NUT
 2. WITH NUT
- HOUSING STYLE
 2. STANDARD TYPE W/O NUT HEXAGON HOLE
- EAR OPTION
 0. NORMAL EAR
 2. MOUNT WITH SCREWTHREAD(M2)
- CONTACT AREA PLATING
 1= Pd/Ni 40 μ"
 2= Pd/Ni 30 μ"
 3= Pd/Ni 20 μ"
 4= Pd/Ni 10 μ"
 5= AU 30 μ"

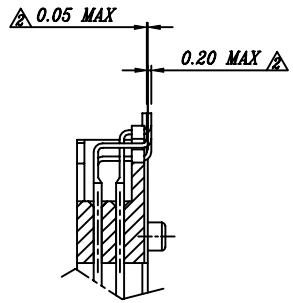
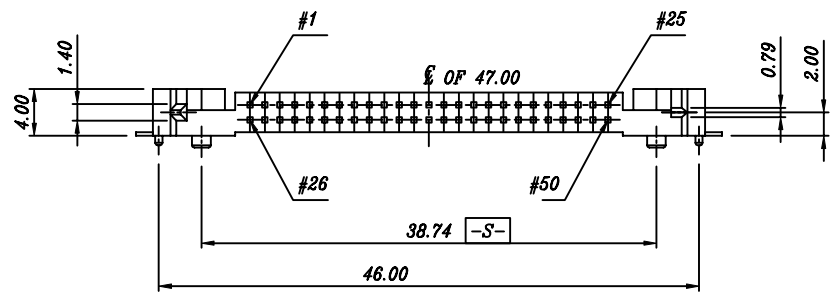
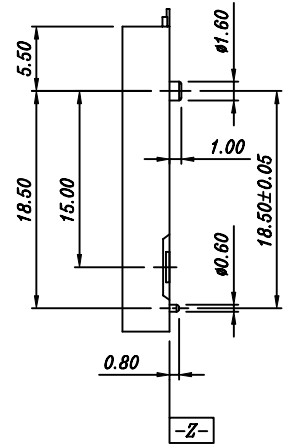
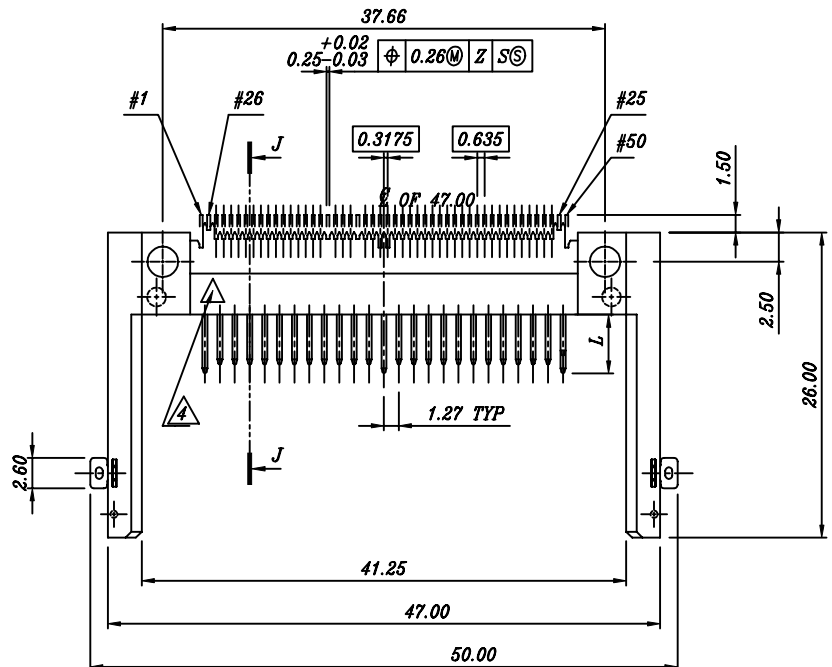

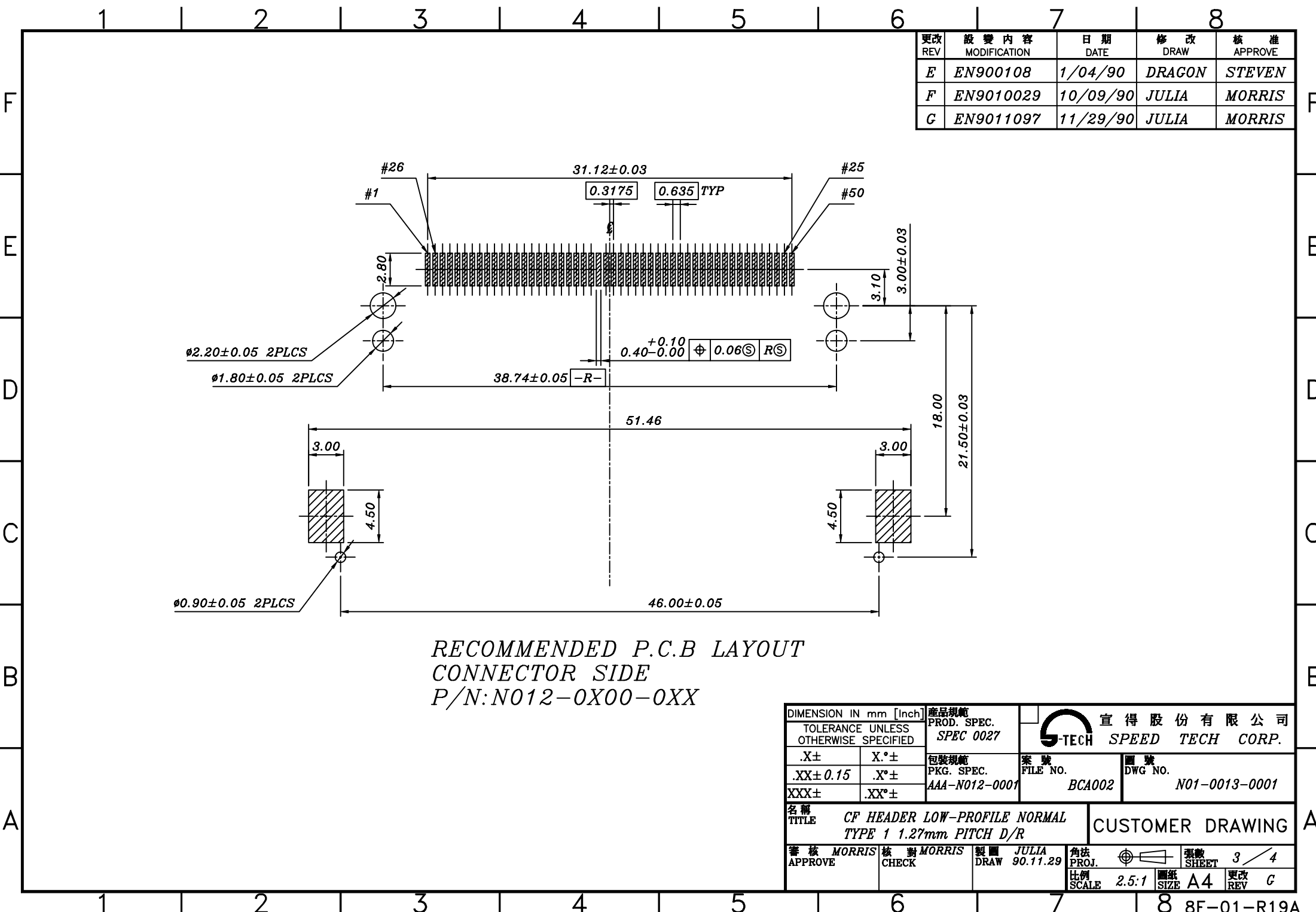

SECTION J-J
SCALE 1.5:1

DIMENSION IN mm [Inch]		產品規範 PROD. SPEC.		宣得股份有限公司 TECH SPEED TECH CORP.	
TOLERANCE UNLESS OTHERWISE SPECIFIED		SPEC 0027		圖號 DWG NO.	
.X±	X.°±	包裝規範 PKG. SPEC.	案號 FILE NO.	圖號 DWG NO.	
.XX±0.15	.X°±	AAA-N012-0001	BCA002	N01-0013-0001	
XXX±	.XX°±	名額 TITLE			
CF HEADER LOW-PROFILE NORMAL TYPE 1 1.27mm PITCH D/R				CUSTOMER DRAWING	
審核 MORRIS APPROVE	核對 MORRIS CHECK	製圖 JULIA DRAW 90.11.29	角法 PROJ.	張數 SHEET	2 / 4
比例 SCALE		圖紙 SIZE	更改 REV		
1.5:1		A4	G		



更改 REV	設 變 內 容 MODIFICATION	日 期 DATE	修 改 DRAW	核 准 APPROVE
E	EN900108	1/04/90	DRAGON	STEVEN
F	EN9010029	10/09/90	JULIA	MORRIS
G	EN9011097	11/29/90	JULIA	MORRIS

RECOMMENDED P.C.B LAYOUT
CONNECTOR SIDE
P/N: N012-0X00-0XX

DIMENSION IN mm [Inch]		產品規範 PROD. SPEC. SPEC 0027		 宣得股份有限公司 SPEED TECH CORP.	
TOLERANCE UNLESS OTHERWISE SPECIFIED		包裝規範 PKG. SPEC. AAA-N012-0001		案 號 FILE NO. BCA002	圖 號 DWG NO. N01-0013-0001
.X±	X.°±	.XX±0.15	.X°±	名 稱 TITLE CF HEADER LOW-PROFILE NORMAL TYPE 1 1.27mm PITCH D/R	
XXX±	.XX°±	審 核 MORRIS APPROVE		核 對 MORRIS CHECK	
		製 圖 JULIA DRAW 90.11.29		角 法 PROJ. 	
		比 例 SCALE 2.5:1		圖 紙 張數 SIZE A4 SHEET 3/4	
				更 改 REV G	

